



A I R C R A F T

P.O. Box 3149  
Albany, GA 31706-3149  
300 Old Pretoria Road  
Albany, GA 31721  
Phone: 229.883.1440  
Fax: 229.439.9790  
[www.thrushaircraft.com](http://www.thrushaircraft.com)

# SERVICE BULLETIN

## No. SB-AG-61

Revision A 08/13/2014

Fuel Filter Replacement on S2R-H80 Airplanes

---

JAMES ALMAN

VICE PRESIDENT ENGINEERING

**AIRPLANES AFFECTED:**

NOTE: THE SERIAL NUMBERS BELOW REPRESENT ALL THRUSH S2R AIRPLANES AFFECTED BY THIS SERVICE BULLETIN.

**MODEL**

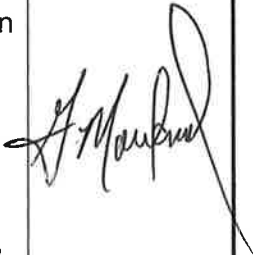
**SERIAL NUMBERS**

S2R-H80

H80-101 & UP

### LOG OF REVISIONS

**NOTE:** Re-formatting and correction of typographical errors is not considered revision. True revisions are indicated by a dark vertical line at the right margin of the lines revised.

Rev.	Page	Description of Revision	By:	FAA Approval
IR	All	New Document Initial Release.	G. Moreland	
A	All iii Pg. 2  Pg.3  Pg. 16 Pg. 21 & 25	Change Rev Level to A. Updated the Log of Revisions for Rev A AN924-8: Changed Qty to 2. 1 used on FWD Firewall also. Deleted AN960-816 due to dwg error. Change Qty AN960-1216 from 2 to 5. Changed Qty MS3367-2-9 from 50 to 10. Changed Qty MS25036-102 from 2 to 4. Corrected part number for Circuit Breaker. Reduced size of split tubing from 3/8" to 1/4" And Changed Part number from TT038 to TT014. Changed washer from AN960-816 to -1216. Changed Split Tubing from 3/8" to 1/4" and Corrected part Number From TT038 to TT014.		

# TABLE OF CONTENTS

TOPIC	PAGE
LOG OF REVISIONS .....	iii
TABLE OF CONTENTS.....	iv
1 PURPOSE AND REASON FOR PUBLICATION.....	1
2 SCOPE/COMPLIANCE .....	1
3 BY WHOM WORK WILL BE ACOMPLISHED.....	1
4 APPROVAL .....	1
4.1 THRUSH AIRCRAFT, INC. APPROVAL.....	1
4.2 FAA APPROVAL.....	1
5 MAN HOURS.....	1
5.1 REMOVAL AND MODIFICATION .....	1
6 SPECIAL TOOLS .....	1
NONE .....	1
7 NEW PARTS AND MATERIAL .....	2
7.1 PARTS REQUIRED ARE FURNISHED BY THRUSH AIRCRAFT.....	2
8 MODIFICATION INSTRUCTIONS .....	4
8.1 REMOVE APPLICABLE SKINS.....	4
8.2 DISCONNECT BATTERY AND DRAIN FUEL FILTER.....	4
8.3 DISCONNECT FUEL PUMP CANNON ELECTRICAL CONNECTOR: .....	7
8.4 REMOVE FUEL PUMP AND FUEL FILTER .....	9
8.5 DRILL SKIN AND ADD GROMMET .....	13
9 PREPARE FUEL PUMP FOR ASSEMBLY IN AIRPLANE.....	14
10 PREPARE FUEL FILTER FOR ASSEMBLY IN AIRPLANE.....	15
11 ATTACH FUEL FILTER TO FIREWALL .....	16
12 ASSEMBLE FUEL PUMP, TUBING AND WIRES .....	17
13 DISCONNECT EXISTING HOSES & ROUTE AND CONNECT NEW HOSES.....	22
14 ASSEMBLE PLACARDS, CIRCUIT BREAKER, LIGHT, AND WIRES .....	25
15 SUPPORT DOCUMENTATION .....	30
16 RECORD OF COMPLIANCE.....	30
17 RESPONSE CARD.....	30

## **1 PURPOSE AND REASON FOR PUBLICATION**

This document defines procedural steps required to replace the existing fuel filter on S2R-H80 airplanes.

## **2 SCOPE/COMPLIANCE**

This Service Bulletin is mandatory for all S2R airplanes included in the table labeled "AIRPLANES AFFECTED" which is included herein on page ii of this document.

Incorporation of this Service Bulletin will ensure that the H80 engine is protected from fuel contamination.

## **3 BY WHOM WORK WILL BE ACOMPLISHED**

The work is to be accomplished by an FAA licensed A&P mechanic, or foreign equivalent. The action must be recorded in the airplane log book and signed off by the mechanic.

## **4 APPROVAL**

### **4.1 THRUSH AIRCRAFT, INC. APPROVAL**

This Service Bulletin is approved by Thrush Aircraft, Inc. Proper execution of this Service Bulletin is required to prevent contamination in the fuel system.

### **4.2 FAA APPROVAL**

The resultant alteration to the affected aircraft described by sections 9 through 15 herein has been shown to comply with the applicable Federal Aviation Regulations and is FAA Approved.

## **5 MAN HOURS**

### **5.1 REMOVAL AND MODIFICATION**

The total time required for incorporating SB-AG-61 is as follows:

- 12 Hours for the H80 Airplanes. (2 Mechanics)

## **6 SPECIAL TOOLS**

**NONE**

**7 NEW PARTS AND MATERIAL****7.1 PARTS REQUIRED ARE FURNISHED BY THRUSH AIRCRAFT.**

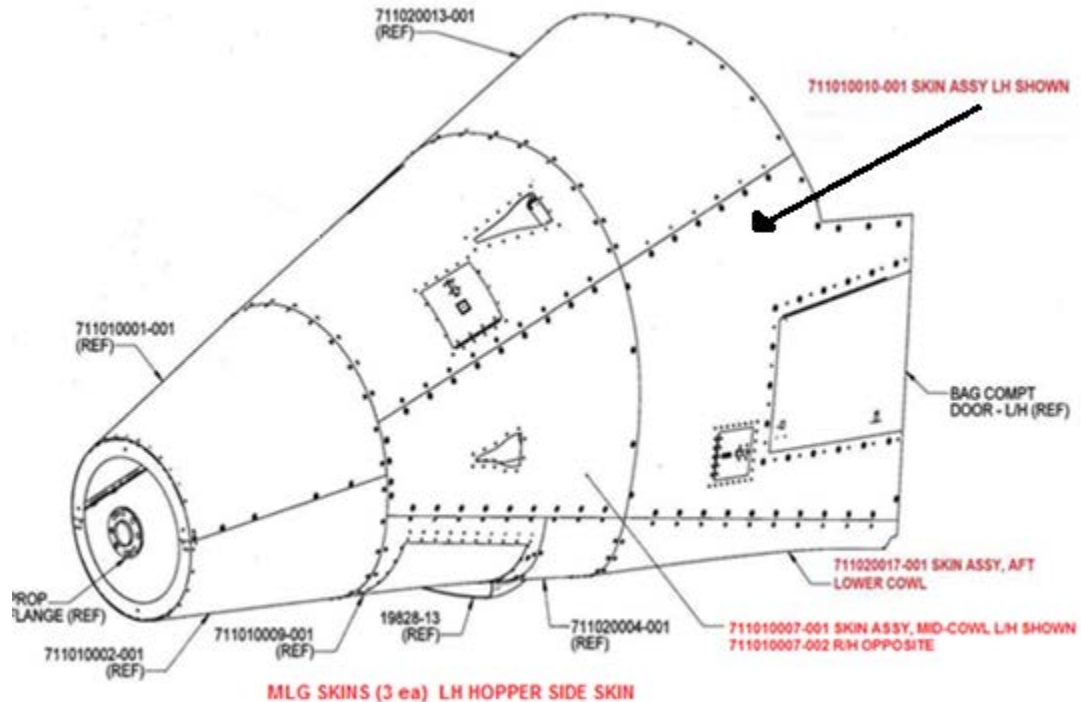
<b>PART #</b>	<b>DESCRIPTION</b>	
1743640-19	FUEL FILTER ASSEMBLY	1
282010006-001	FIREWALL FITTING #12 to #8	1
M83248-1-912	O-RING	2
MS9387-12	O-RING	ALTERNATE
AN919-19	REDUCER	2
MS206154M	RIVETS	4
AN924-8	NUT	2
AN816-4	ADAPTER	1
M83248-1-904 (MS9387-04)	O-RING	1
AN910-1J	PIPE COUPLING	1
CCA-1550	QUICK DRAIN	1
111514E0240D000	HOSE	1
111417-8D0490	HOSE	1
282020007-001	BRACKET	1
AN4-3A	BOLT	4
AN960-416	WASHER	4
AN960-1216	WASHER	5
MS21919WDG24	CLAMP	3
AN3-5A	BOLT	3
AN960-10	WASHER	22
MS21044N3	NUT	11
531420002-001	FIREWALL DOUBLER	1
282010015-001	WELDED FITTING ASSY	1
282060001-001	FUEL PUMP	USE EXISTING
MS35489-11	GROMMET	1
.25 x .063 TUBING	TUBING	1 FT
5053K44	MALE TUBE FITTING	1
AN815-8	UNION	1
M83248-1-908 (MS9387-08)	O-RING	2
MS21919WDG38	CLAMP	2
282010007-001	BRACKET ASSY	1
MS3367-2-9	TY-RAP	10
MS3367-2-4	TY-RAP	25
MS35489-20	GROMMET	1
MS3106A12S-3S	CANNON PLUG	1
MS3057-4A	BACKSHELL	1
29043 22	22 AWG ELECTRICAL WIRE	18 FT
MS25041-4	LIGHT AMBER	1
GE-327	BULB	1
21436-301	PLACARD	1
21436-297	PLACARD	1
21436-299	PLACARD	1
MS25036-102	CRIMP TERMINAL LUG	4
MS25036-103	CRIMP TERMINAL LUG	4

7277-2-1	CIRCUIT BREAKER	1
TT014NPBS	BLACK SPLIT TUBING 1/4"	18FT
MS21044N4	NUTS	2
AN4-7A	BOLTS	2
AN995B (.040) or 05-06650	SAFETY WIRE	5 INCHES
19164-0013	Red Splice	4
AN526-1032R8	Screw	6
AN3-4A	Bolt	3
MS21919WDG18	Clamp	1
H80-1MM	H80 Airplane Maintenance Manual, Single and Dual Cockpit - Revision 3 or later approved revision.	
AFM H8001	H80 Airplane Flight Manual Single and Dual Cockpit – Revision A or later approved revision	

## 8 MODIFICATION INSTRUCTIONS

### 8.1 REMOVE APPLICABLE SKINS.

Remove the skins that are high-lighted in Figure 61-1 from the fuselage forward assembly to gain access to areas where work is to be performed.



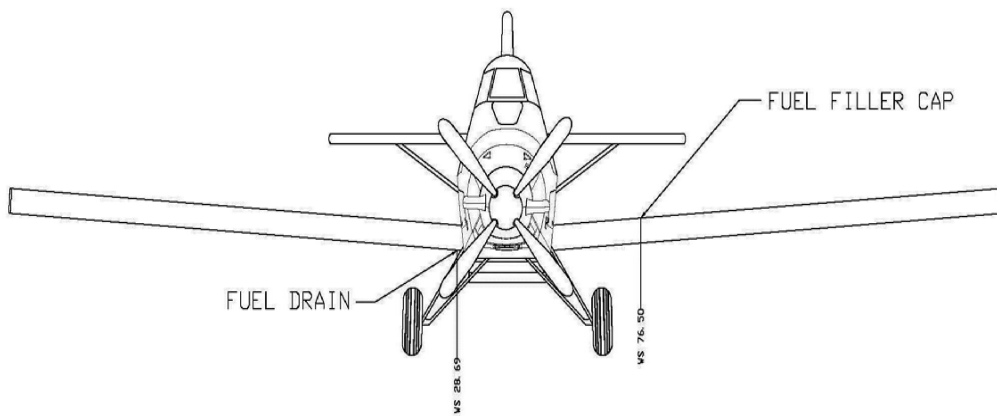
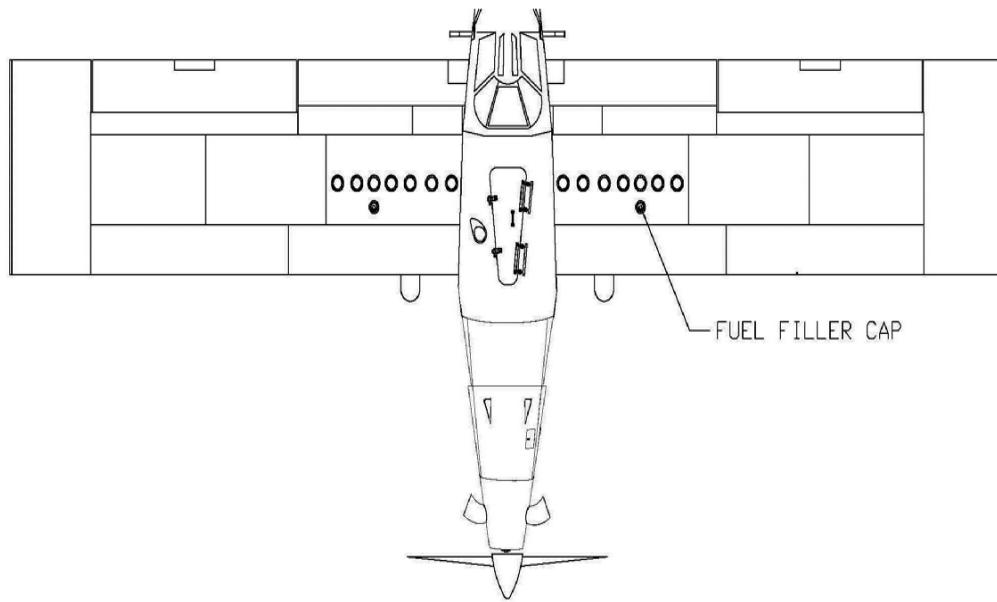
**Figure 61-1 Skins to be Removed**

### 8.2 DISCONNECT BATTERY AND DRAIN FUEL FILTER

Turn airframe fuel shutoff valve to “OFF” position. Obtain adequate containers to catch fuel released.

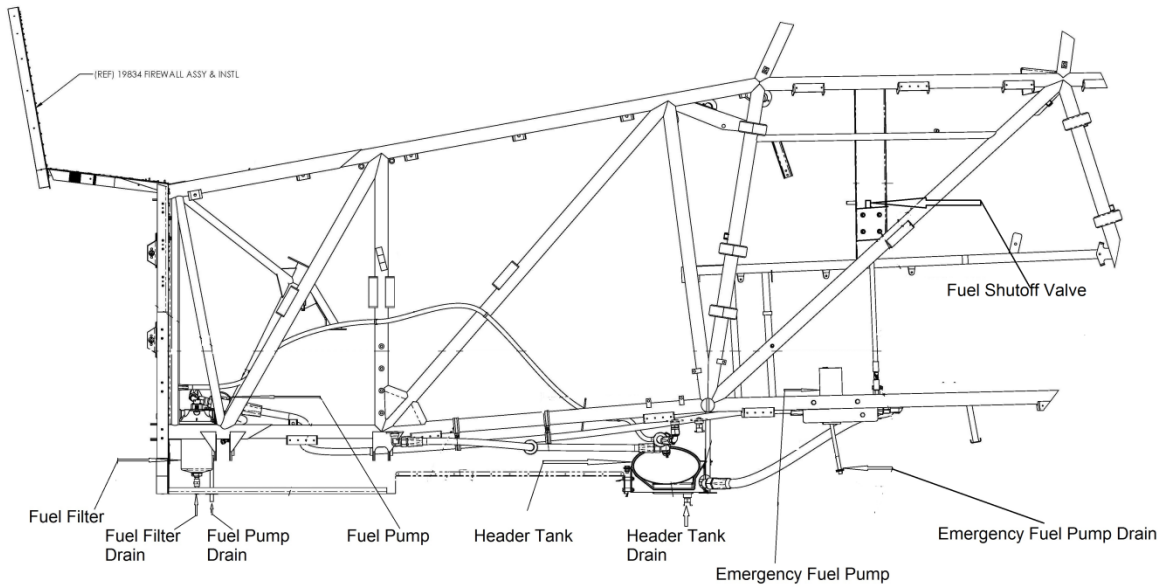
Drain the fuel Filter.



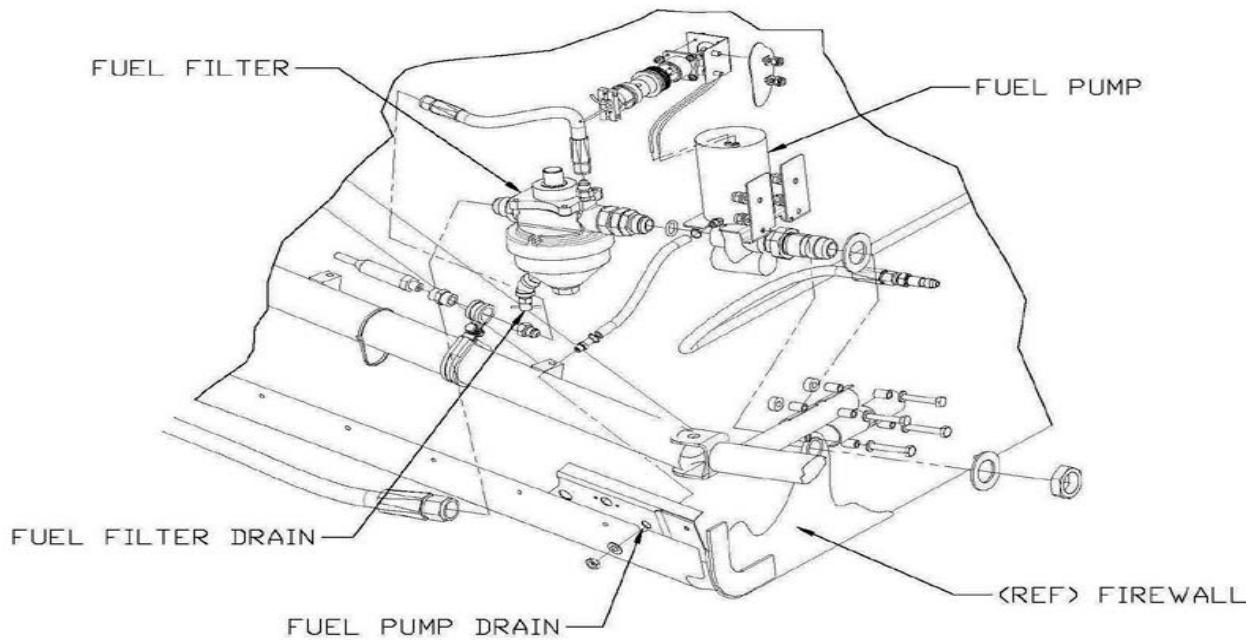


ALL LOCATIONS ARE TYP FOR BOTH WINGS

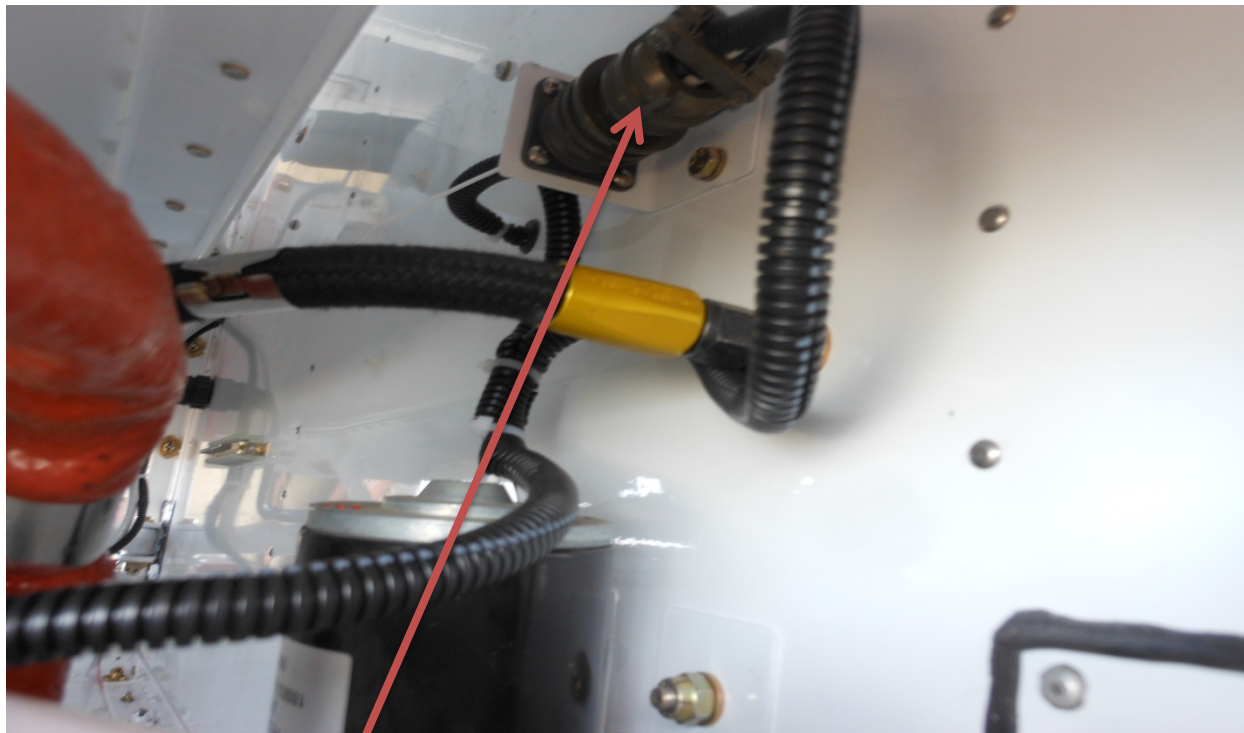
**Figure 61-2 Wing Tank Fuel Drain Typical**



**Figure 61-3: Header Tank Fuel Drain**

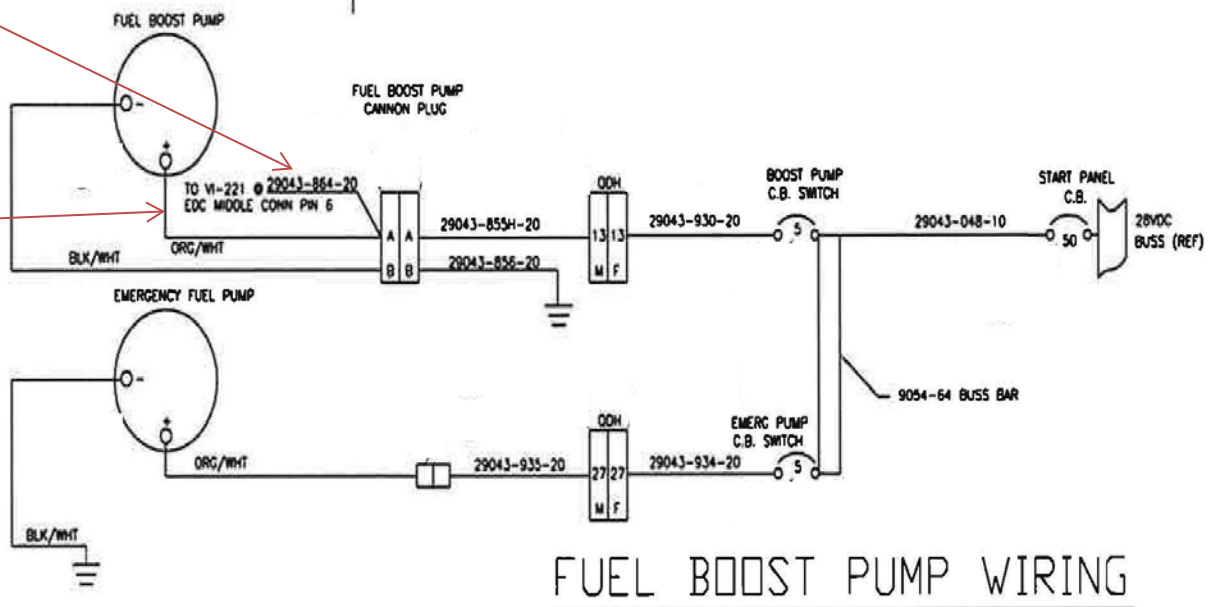


**Figure 61-4: Firewall Fuel Filter Drain**

**8.3 DISCONNECT FUEL PUMP CANNON ELECTRICAL CONNECTOR:**

**Figure 61-5**

- a. Disconnect Cannon Connector.
- b. Remove the backshell so that the wires are exposed
- c. Extract the wires from the cannon plug. Make a tag to identify each wire.
- d. Clip Ty-Raps from the Black Split Tubing That Cover the Wires Attached to the Fuel Pump and pull back the tubing.
- e. There should be a long wire connected to pin A and it should be labeled 29043-864-20 pump power and clip off the connector pin. See figure 61-5a. There should be a short orange and white wire out of the fuel pump to pin A. Label as pump power and clip of the connector pin.
- f. The wire connected to pin B should be labeled as pump ground and clip the connector pin.

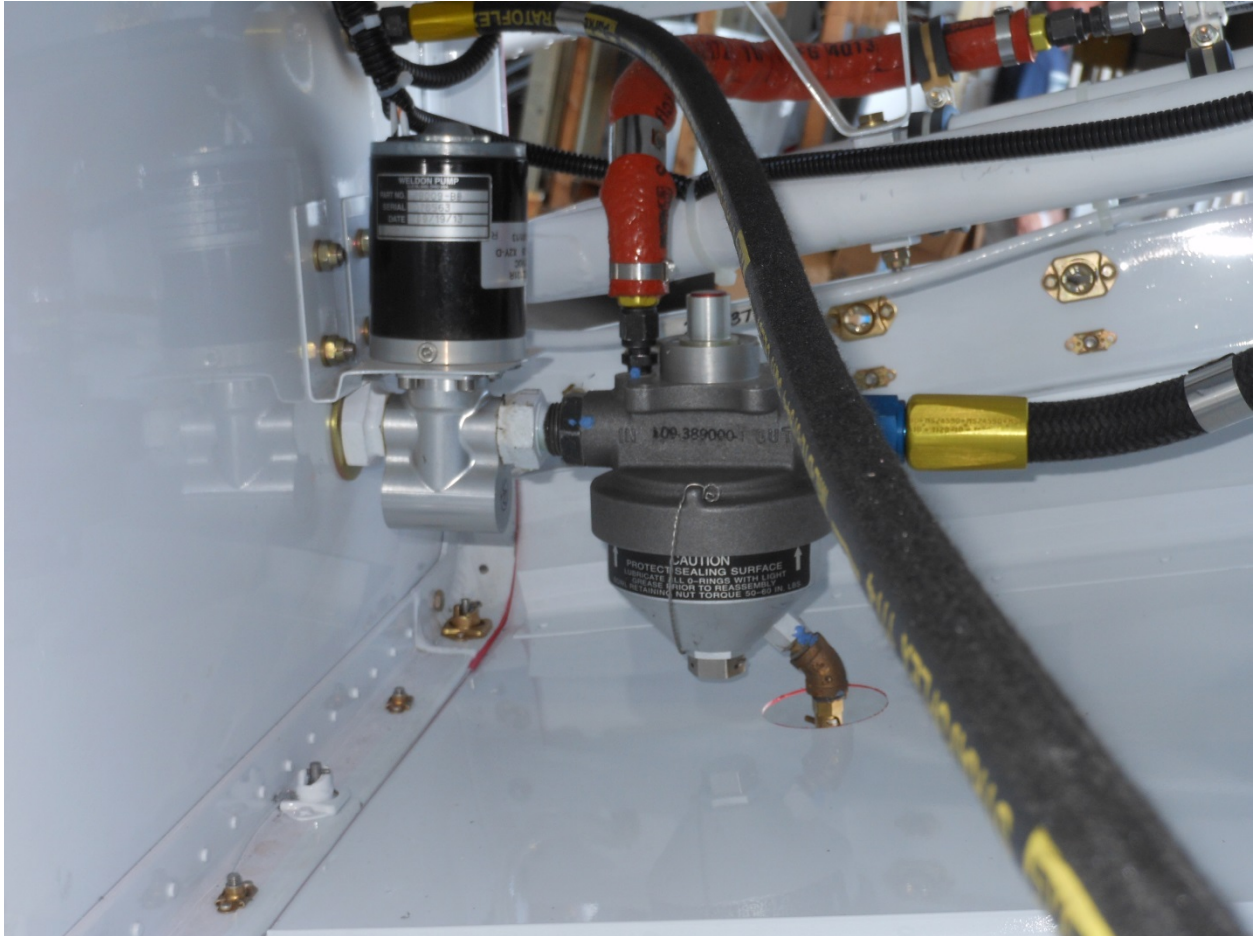


**Figure 61-5a**

9.3e

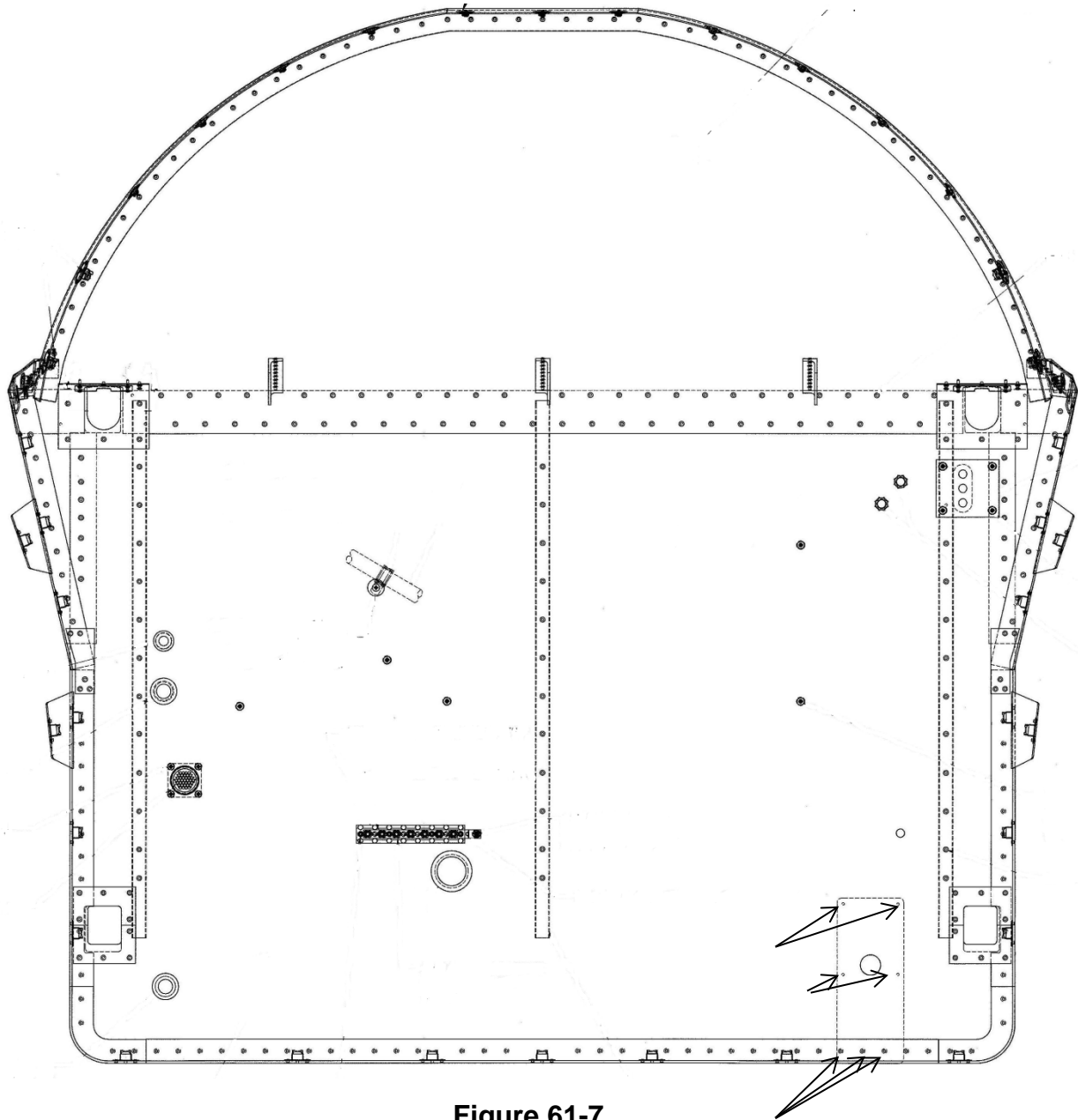
- g. Remove the firewall mounted part of the cannon connector and associated hardware.
- h. Clip Ty-Raps from the Black Split Tubing and pull back tubing exposing wires.
- i. Extract the wire from Pin A and label as 29043-855H-20 Pump Power and clip connector pin.
- j. Extract the wire from Pin B and clip the connector pin as the wire will not be re-used.
- k. Pull the wire through the firewall to the aft side and let hang for later use.

#### 8.4 REMOVE FUEL PUMP AND FUEL FILTER



**Figure 61-6**

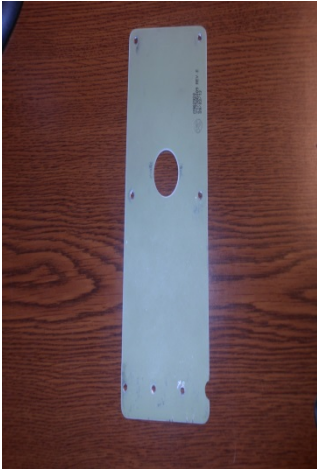
- a. Disconnect The Red, Fuel Pressure Hose From The Fuel Filter. This Hose Will Be Reconnected In A New Location Later.
- b. Disconnect The Black Hose From The Fuel Filter. Disconnect The Other End Of This Hose Also. This Hose Is No Longer Required.
- c. Remove The Hose On The Aft Side Of The Firewall That Attaches To The Fuel Pump.
- d. Remove fuel pump drain connection from fuel pump and C-Channel. Discard.
- e. Remove The Nut And Washer On The Aft Side Of The Firewall Where The Hose Was Just Removed. Remove the Fuel Pump and Filter as an Assembly.
- f. Disconnect The Fuel Pump From The Fuel Filter And Remove The Fuel Filter. This Fuel Filter Is No Longer Required.
- g. Remove The Inlet And Outlet Fittings From The Fuel Pump As They Won't Be Required.



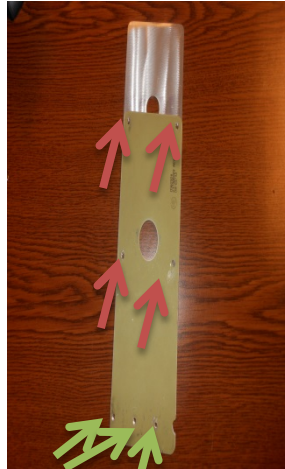
**Figure 61-7**

- h. Drill Out The Seven Rivets That Attach The Firewall Doubler To The Aft Side Of The Firewall Using A #30 Drill.

- i. Take This Doubler, Figure 61-8, And Use As A Template For Drilling **three** Rivet Holes in the bottom of the new, blank 531420002-001, Firewall Doubler, Figure 61-9.
- j. Also use the template to open up the **four** existing #30 holes in the template and drill through the 531420002-001 new doubler to a diameter of 0.197/0.191.
- k. Slide the template up to the top of the new doubler and drill through the template and the new doubler to a diameter of 0.197/0.191. Figure 61-10.



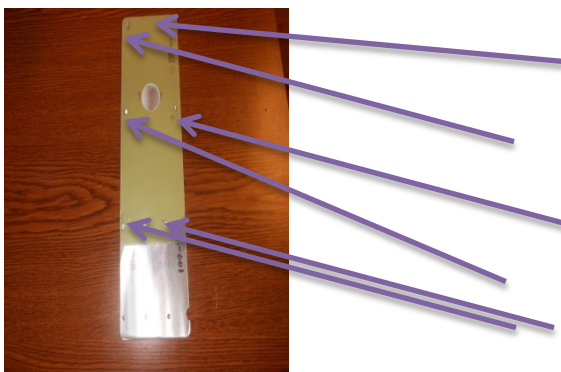
**Figure 61-8**



**Figure 61-9**

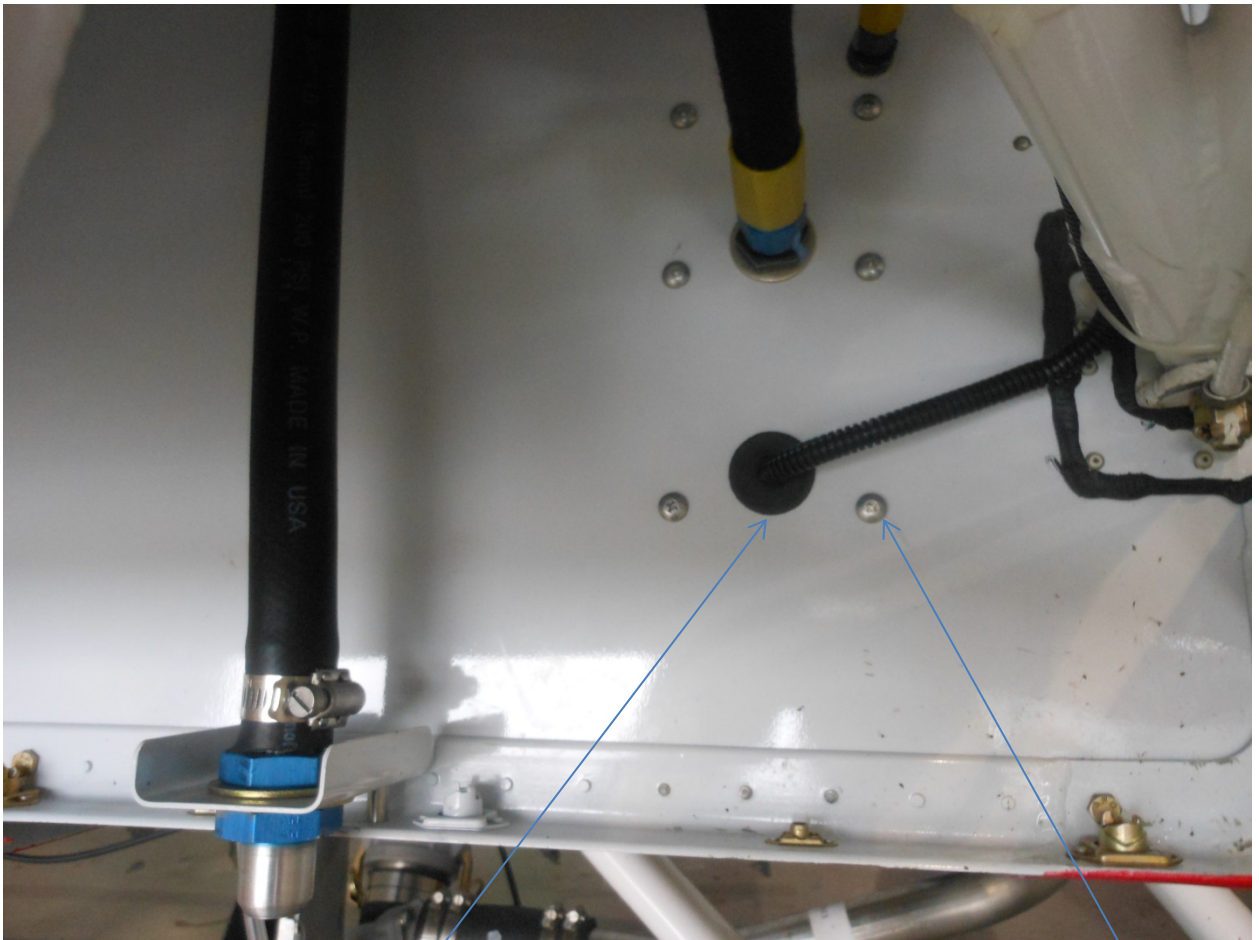


**Figure 61-10**



**Figure 61-10a**

- l. Use the newly drilled doubler to locate and drill the new 0.197/.0191 holes and open up the existing firewall holes to a diameter of 0.197/0.191. **Six holes** see figure 61-10a. Six holes
- m. Punch Out A  $\frac{3}{4}$  Inch Hole in the firewall To Match The New Doubler.
- n. Rivet the new doubler to the bottom of the firewall with MS206154M Rivets. Qty 3.



**Figure 61-10b**

- o. Insert A MS35489-20 Grommet to Cover the Bottom Hole in the Doubler and bulkhead.
- p. Finalize the doubler assembly with AN526-1032R8 screws on the forward side of the firewall and AN960-10 washers and MS21044N3 nuts on the aft side of the firewall. Six each.



## 8.5 DRILL SKIN AND ADD GROMMET



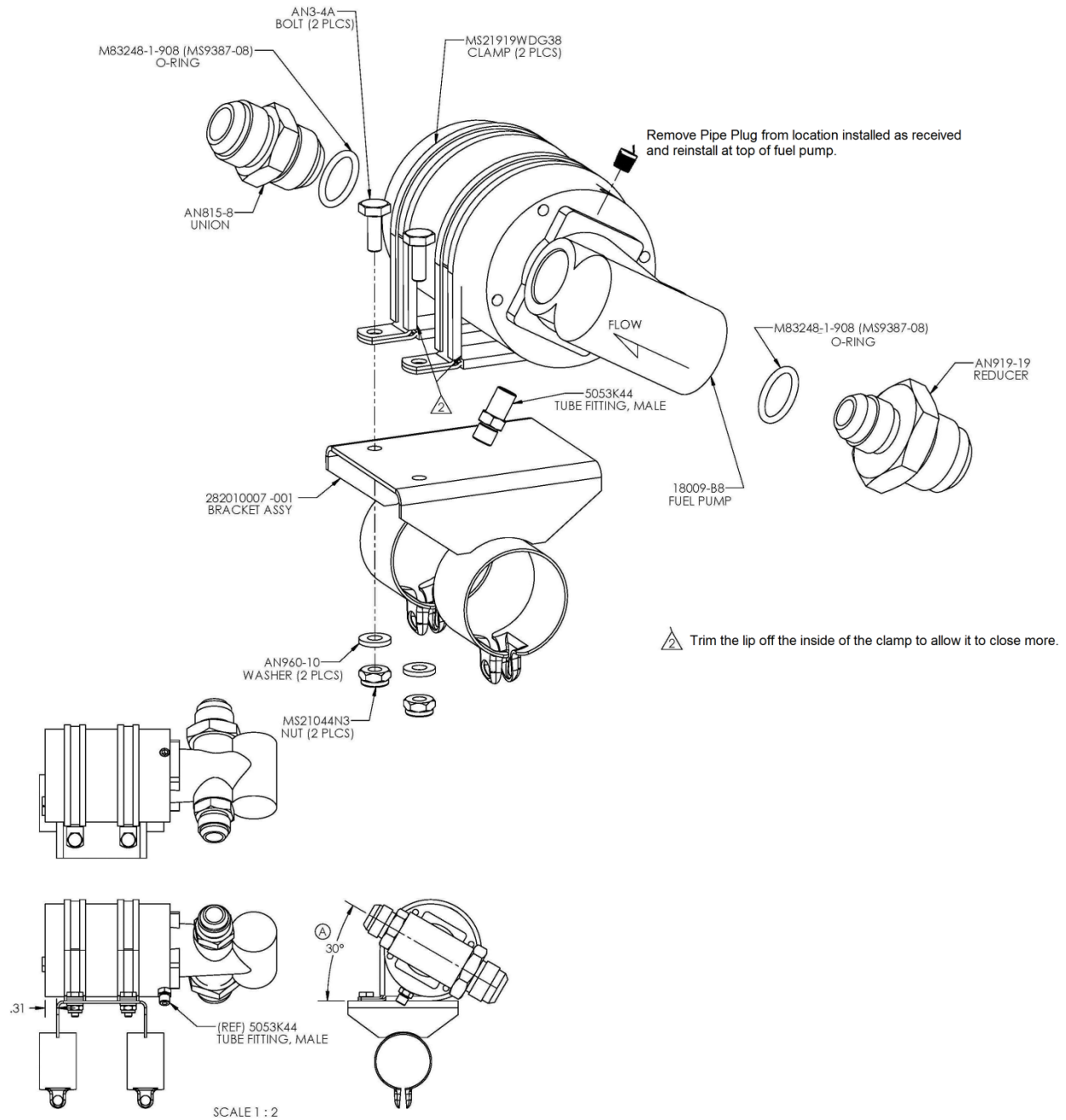
Figure 61-11

HOLE (.62")

HOLE (2")

- a. Drill a .62 Dia Thru Hole. The hole will pass thru the 2 skins and the camloc channel. Locate center of hole in line with existing camlocs and at  $8 \frac{1}{4}$ " from this edge.
- b. Drill a 2.00" Dia Thru hole. Locate the center of the hole  $4 \frac{1}{2}$ " from this edge, And 5" from this edge.
- c. Insert a MS35489-11 Grommet in the camloc channel.
- d. Note: The hole in the MLG Skins will be Drilled Larger to account for the OD of The MS35489-11 Grommet.

## 9 PREPARE FUEL PUMP FOR ASSEMBLY IN AIRPLANE



**Figure 61-12**

- a. Assemble The Components Shown And Pay Attention To Orientation.

# 10 PREPARE FUEL FILTER FOR ASSEMBLY IN AIRPLANE

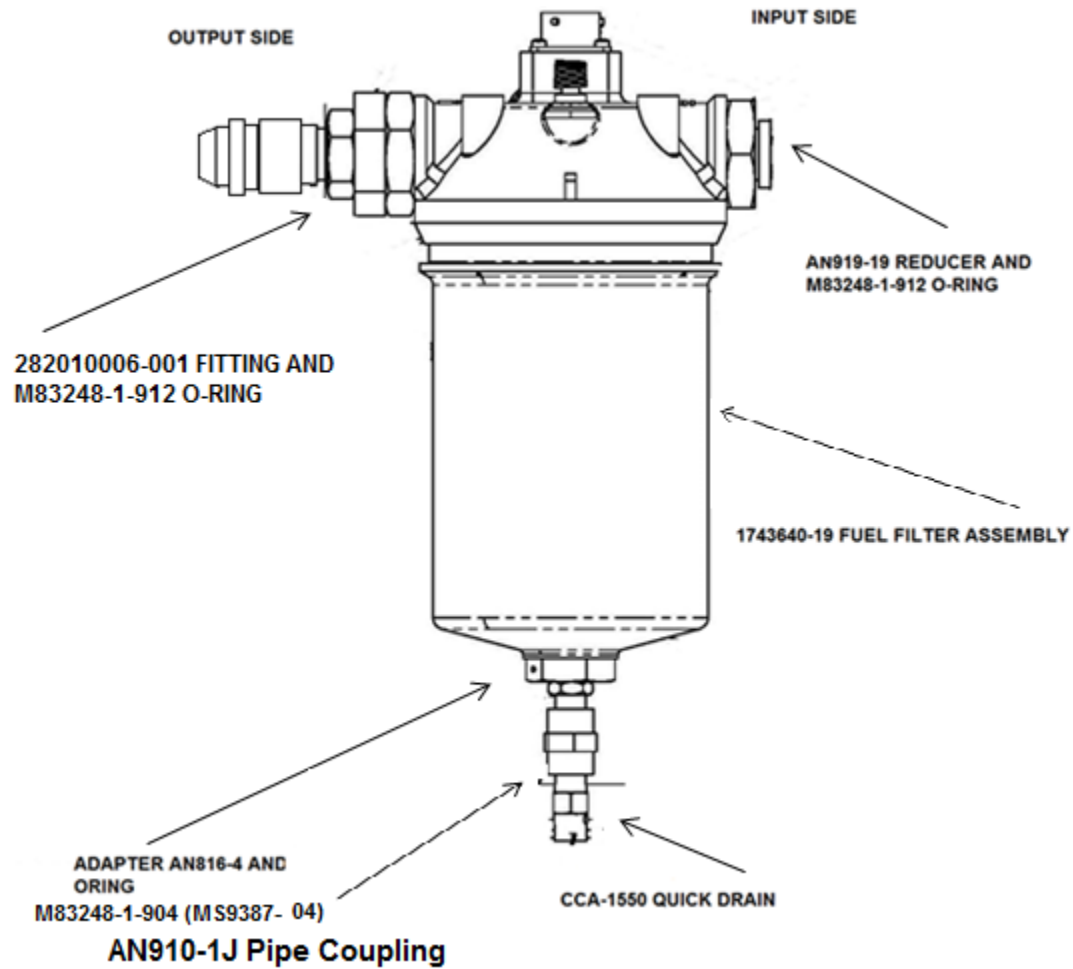


Figure 61-13

- a. Assemble The Components Shown And Pay Attention To Orientation.

## 11 ATTACH FUEL FILTER TO FIREWALL

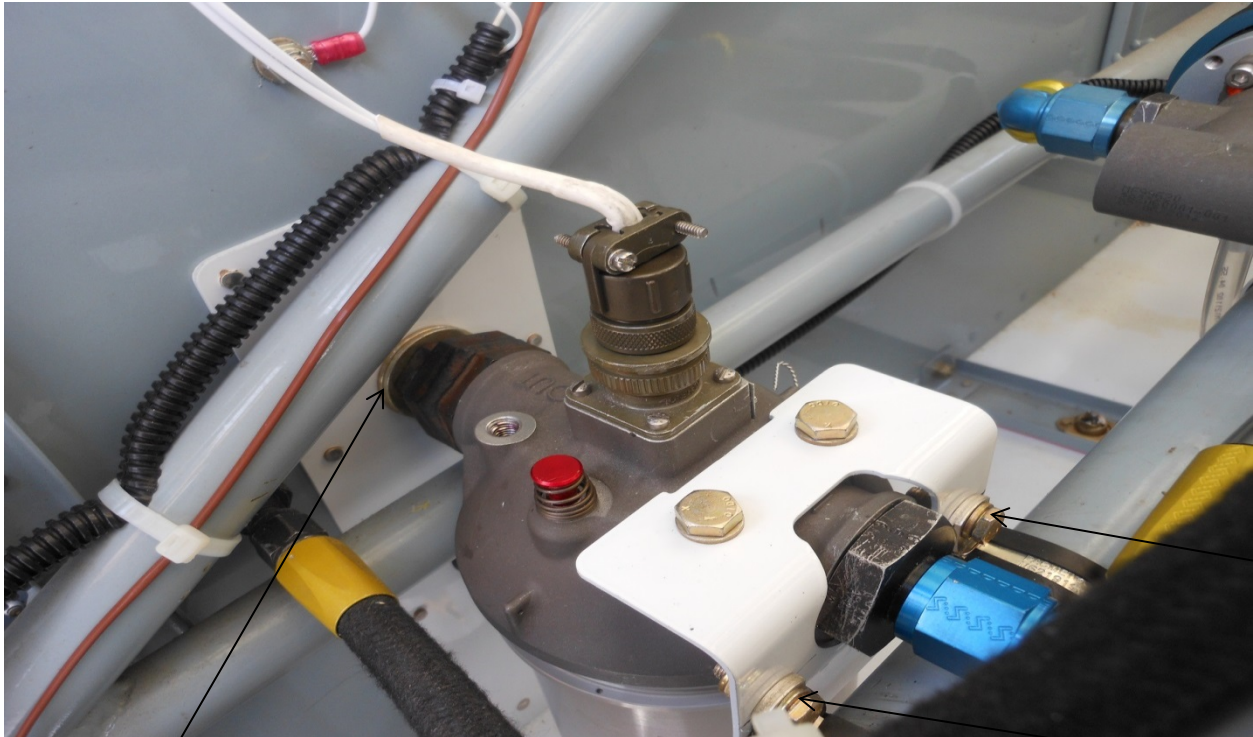
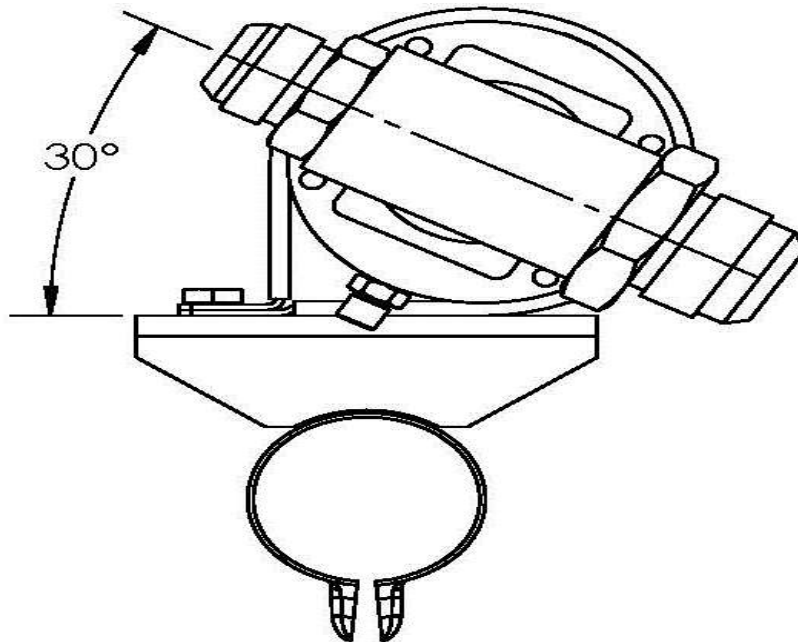


FIGURE 61-14

- a. Position fuel filter for insertion thru firewall. One or two washers, AN960-1216, should be added prior to insertion. Note that the filter is inserted thru doubler that was mounted to the firewall. See Figure 61-10b. Note the filter must be fit into the firewall without the bracket first.
- b. Place another AN960-1216 washer and AN924-8 nut on the opposite side of the firewall to lock the fuel filter in place.
- c. Bracket Must be Installed after Filter is Installed. There is not enough clearance to install as an assembly.
- d. Assemble the bracket, 282020007-001 onto the filter using AN4-3A Bolts and AN960-416 Washers @2 each.
- e. Place (2) MS21919WDG24 clamps around the tube shown and use them to locate and mark holes for the mounting hardware. Use a #10 drill in 2 places. Attach the clamps to the bracket with (2) AN3-5A bolts, (4) AN960-10 Washers, and (2) MS21044N3 Nuts. **Remove bracket and drill the bracket on bench so the filter does not get damaged.**

## 12 ASSEMBLE FUEL PUMP, TUBING AND WIRES



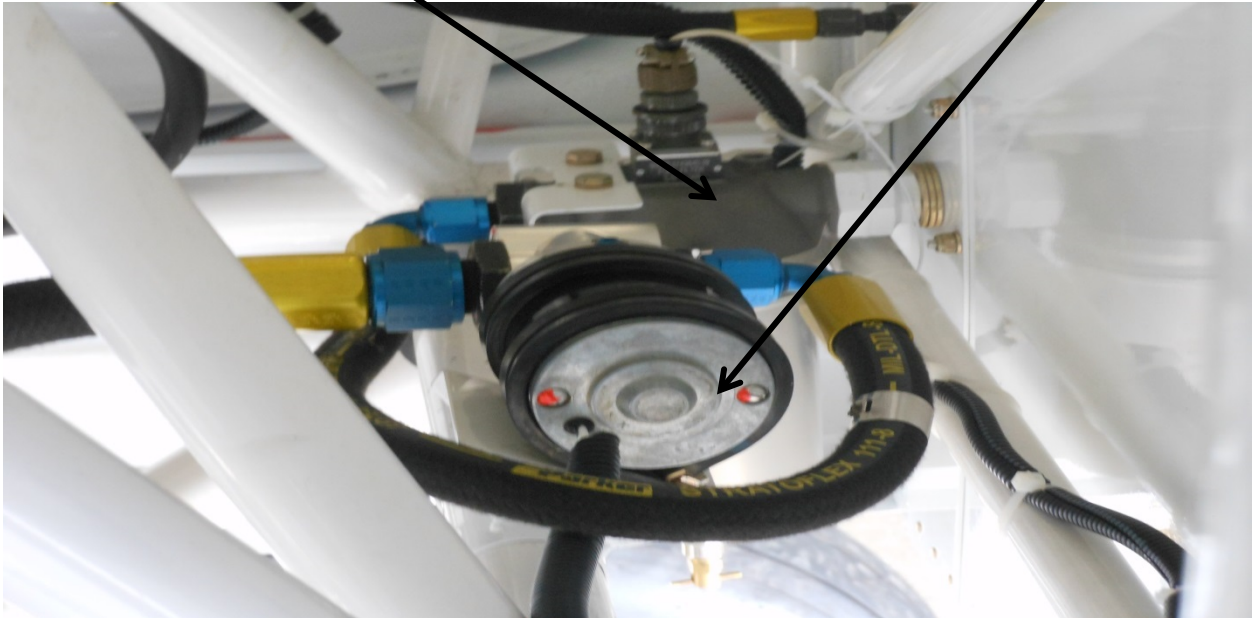
**FIGURE 61-15**

- a. Retrieve The Fuel Pump That Was Assembled In Section 10 Herein And Shown Above.

- b. Place The Fuel Pump Mounting Bracket Over The Tube Shown And Locate Near The Fuel Filter As Shown In Figure 61-16. **Locate fuel pump close enough to the fuel filter to ensure that there is clearance and that the long inlet hose for the pump will not come into contact with the shock strut assembly.**

FUEL FILTER ASSEMBLY

FUEL PUMP ASSEMBLY

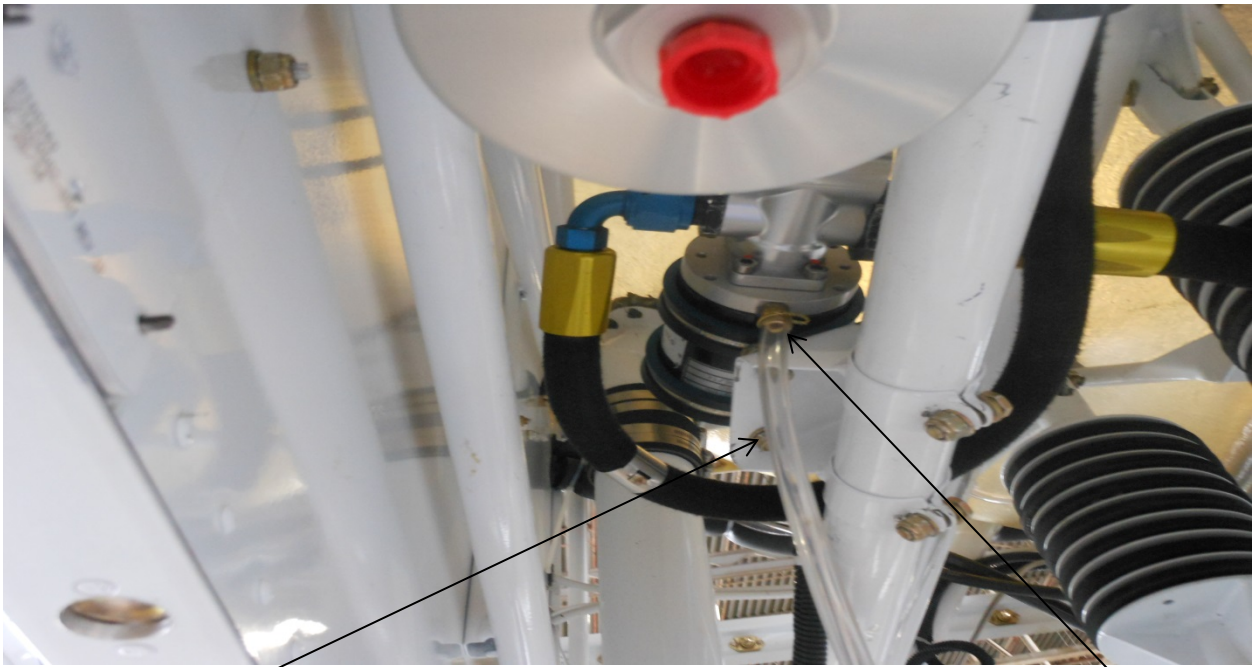


**FIGURE 61-16**  
View from R/H Side



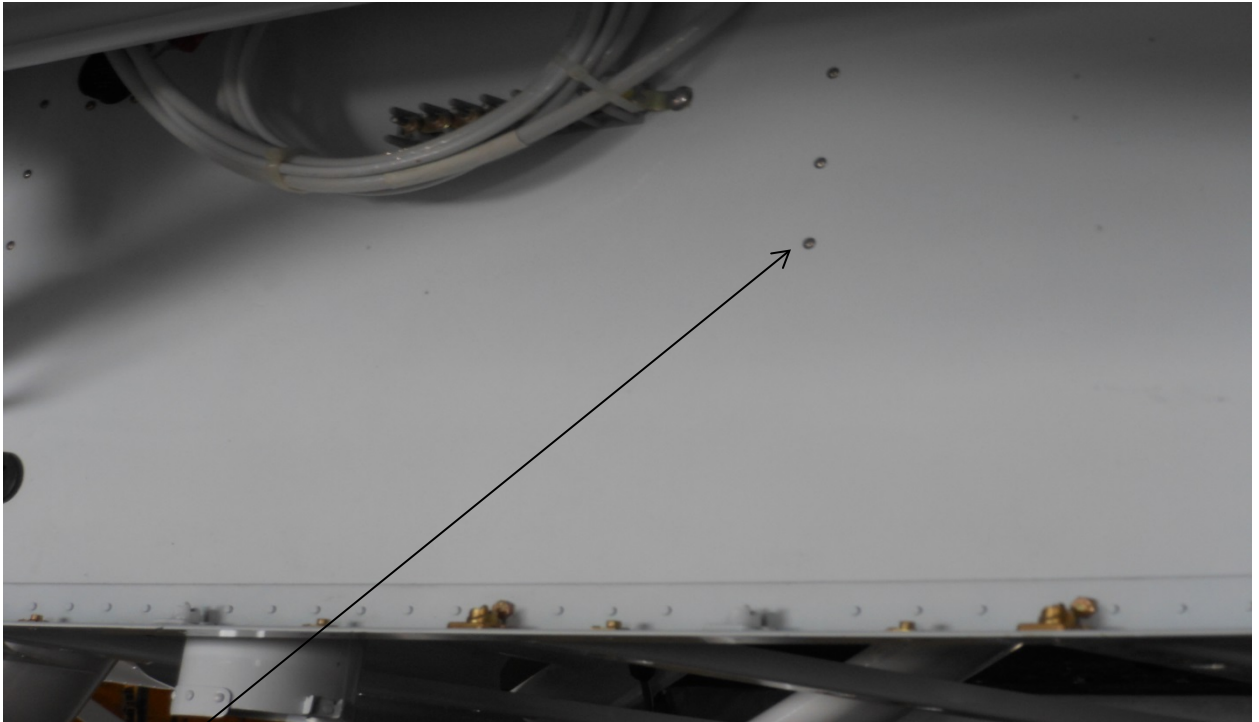
**Figure 61-16a**  
View From L/H Side

- c. Install the following where shown to provide support for the fuel pump inlet hose and keep it away from the shock strut and splice block. **MS21919WDG24 Clamp.** **AN3-5A Bolt, AN960-10 Washer, MS21044N3 Nut.** **MS21919WDG18 Clamp.**



**FIGURE 61-17**

- d. Lock the Fuel Pump Assembly in Place with Hardware As Follows: (2) AN3-4A Bolts, (4) AN960-416 Washers and (2) MS21044N4 Nuts.
- e. Assemble A 1 Foot Length Of .25 X .063 Tubing To The Male Tube Fitting As Shown And Secure In Place With AN995B (.040) OR 05-06600 Brass Safety Wire.
- f. Route The Other End Of The Tubing Through The Grommet In The Camloc Channel And Two Skins. See Figure 61-11 For Details. Trim hose as needed outside of skins at approximately 3 inches.



**Figure 61-17a**

- g. Drill this rivet out using 3/16 inch Drill from the forward side of the firewall.
- h. Spot face the firewall forward and aft side where rivet was removed creating a good surface for and electrical ground.

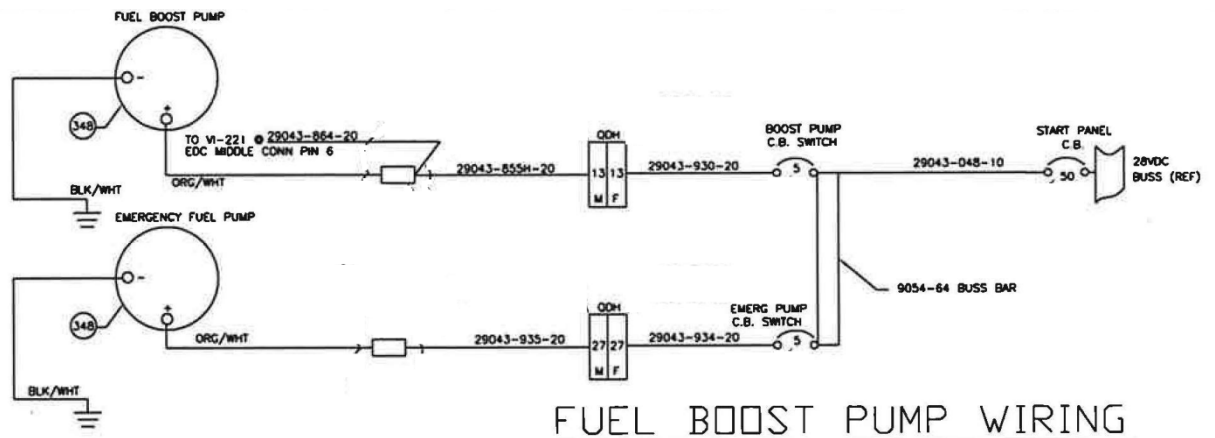


**Figure 61-17b**

- i. Install an AN3-4A and AN960-10 Washer on the forward side of the firewall. Install a MS210443 nut and AN960-10 on the aft side of the firewall. See Figure 61-17b for detail. This is now the terminal to ground the fuel pump.



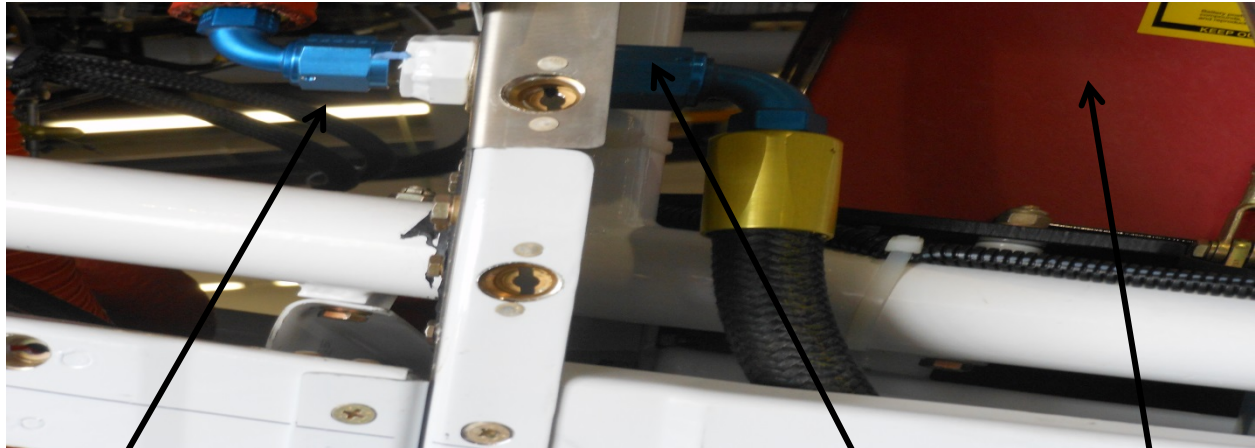
- j. Reverse The Wiring Disconnection Performed In Section 9.3 Herein.
- k. Locate the wire, on the Forward side of the firewall, labeled 29043-864-20 pump power. Pull wire through the grommet installed in the firewall.
- l. Locate the wire, on the aft side of the firewall, labeled 29043-855H-20 Pump Power.
- m. Place these two wires in one end of a 19164-0013 Red Splice and Crimp together.



**Figure 61-5a new**

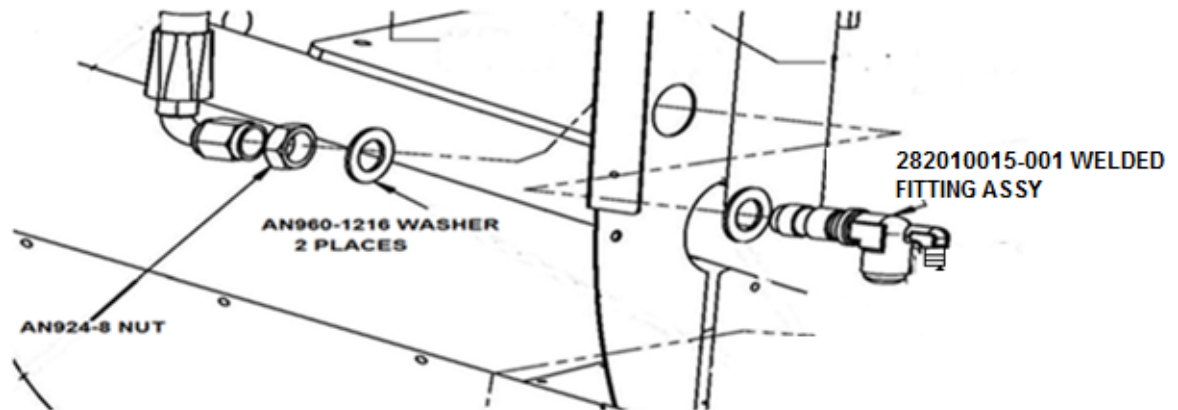
- n. Locate the orange and white wire on the fuel pump labeled pump power and place in the other end of the 19164-0013 Red Splice and Crimp.
- o. Locate the black and white wire on the fuel pump labeled pump ground and crimp on a MS25036-103 Terminal Lug and terminate on the aft side of firewall under nut installed per Figure 61-17b to serve as ground.
- p. Cover all wires with TT014NPBS 1/4" Black Split Tubing.

# 13 DISCONNECT EXISTING HOSES AND ROUTE AND CONNECT NEW HOSES.



**FIGURE 61-18**

- a. Disconnect This Hose At This Junction.
  - b. This Hose Should Already Be Disconnected At This Junction.
  - c. Remove All Hardware Remaining At This Junction And Replace With Hardware Shown In Figure 61-19.
  - d. Reconnect the hose.
- Ref Battery



**FIGURE 61-19**



**FIGURE 61-20**

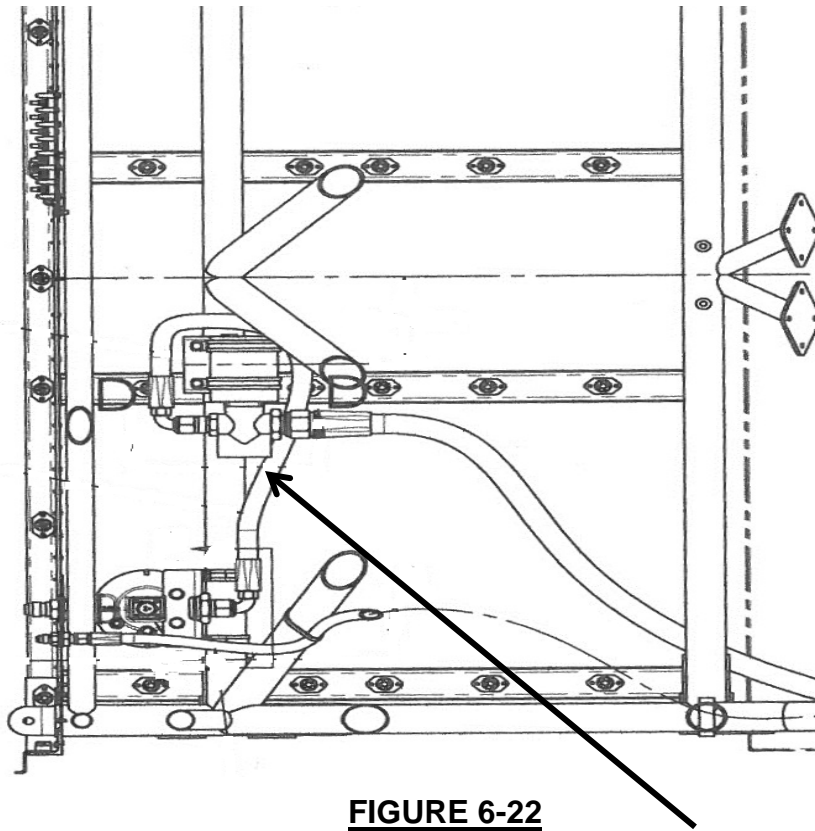
This is a reference view to indicate the way this hose **was routed and secured** to the tube. This is the hose that was disconnected from the fuel filter. See figure 61-6.

- e. Route, Secure, And Connect the Hose to the AN822-4 Elbow Fitting At The Aft Terminal Of The 282010015-001 Fitting. See Figure 61-21.



**FIGURE 61-21**

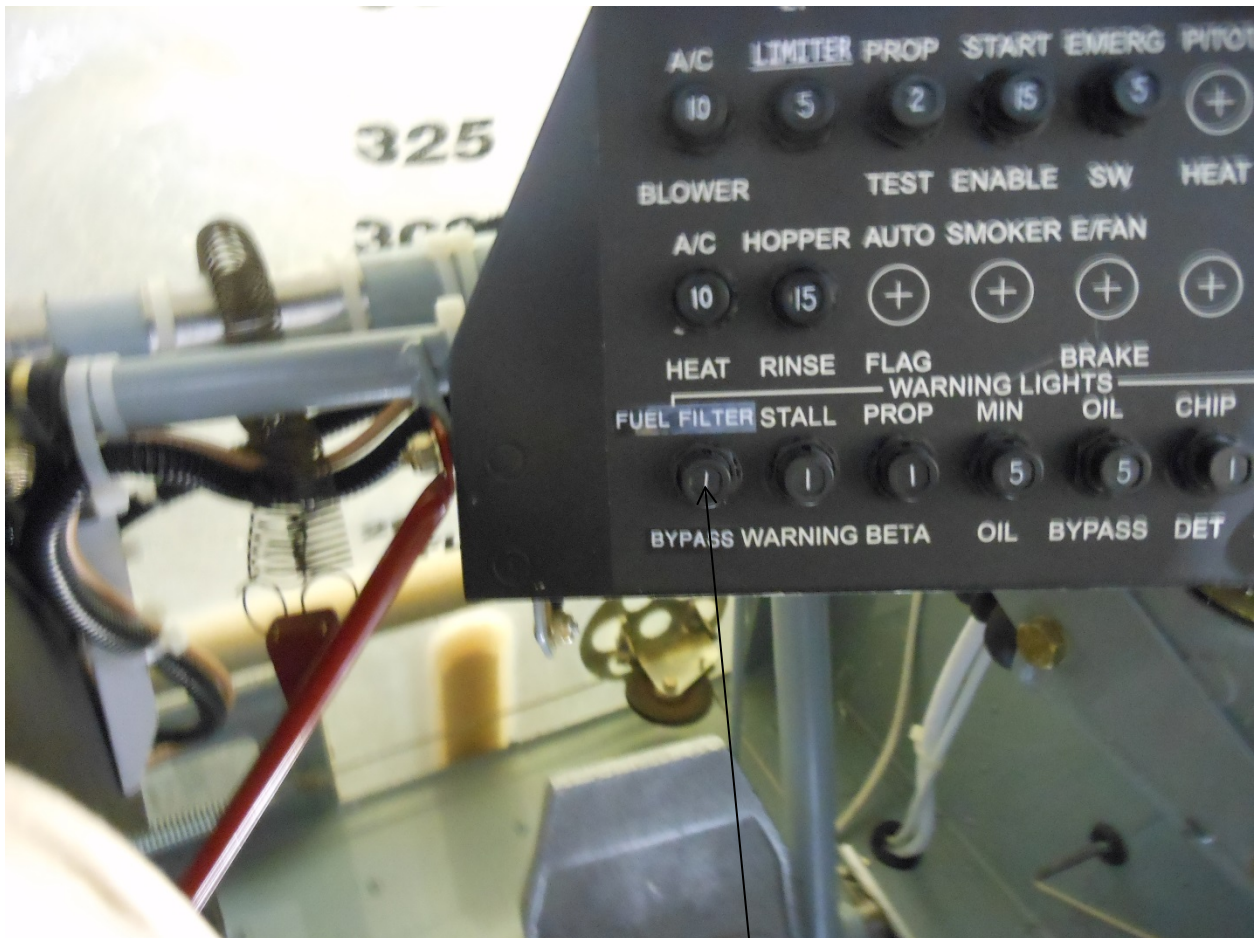
- f. Locate The 111417-8D0490 Hose And Connect One End To The Forward Terminal Of The 282010015-001 Fitting.
- g. Route the other end of the hose to the firewall and connect it to the fuel filter fitting.



**FIGURE 6-22**

- h. Locate The 111514E0240D000 Hose And Connect One End To The Output Side of the Fuel Pump and the Other End to the Input Side of the Fuel Filter.
- i. Connect The Existing Fuel Supply Hose To The Input Side Of The Fuel Filter.

## 14 ASSEMBLE PLACARDS, CIRCUIT BREAKER, LIGHT, AND WIRES



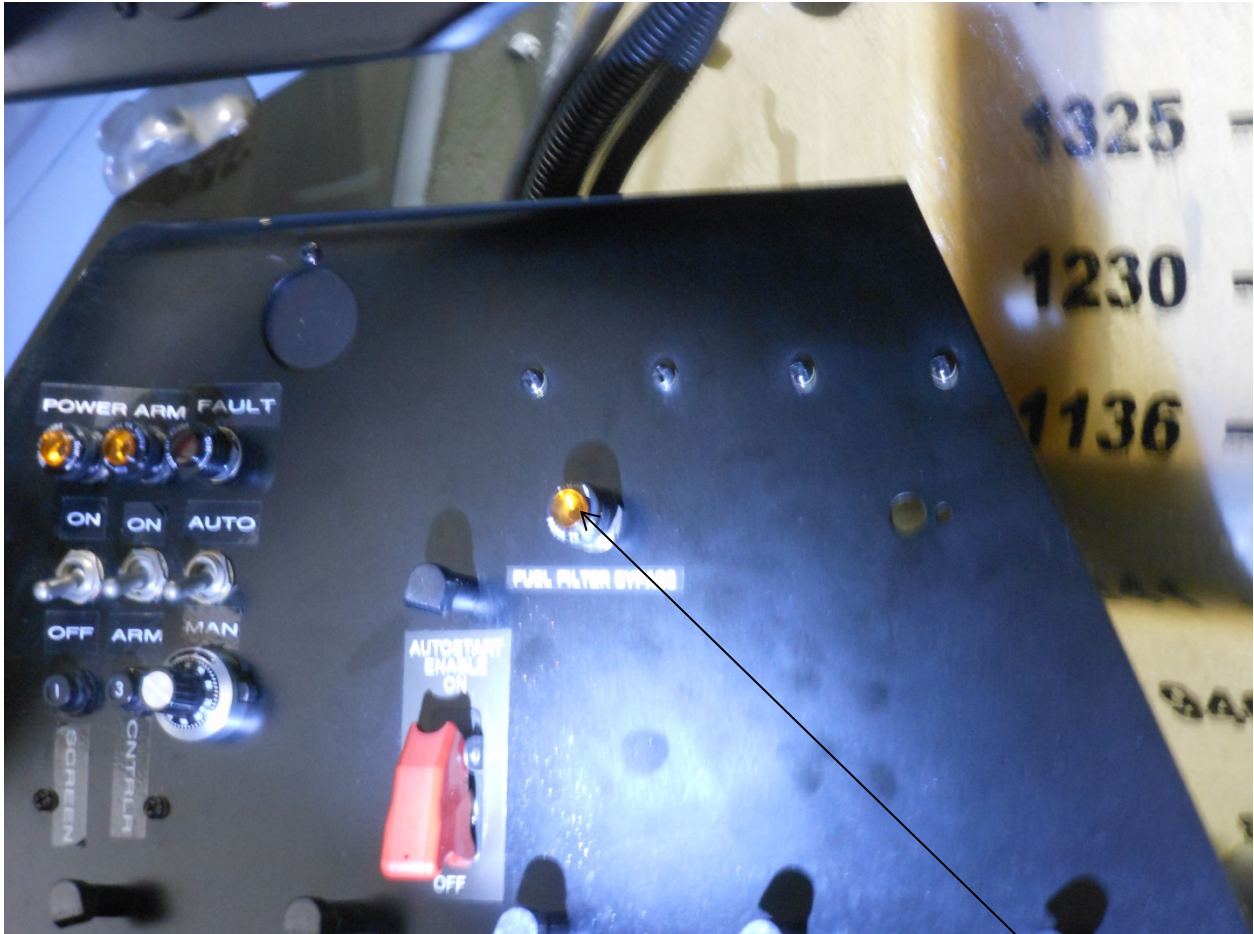
**FIGURE 61-23**

- a. Drill a Dia. 0.437 hole to add a circuit breaker.
- b. Install (1) 7277-2-1 Circuit Breaker in This Location on the Right Hand Instrument panel.
- c. Install the Fuel Filter Placard 21436-297 right above the Circuit Breaker.
- d. Install the Bypass Placard 21436-299 below the Circuit Breaker.

NOTE: Prepare to assemble wires. All wires are to be covered with 1/4" Black Split Tubing (TT014NPBS) and secured with Ty RAPS to prevent them from chafing and prevent vibration.

- e. Crimp (1) Terminal Lug MS25036-103 on the end of a 22 AWG Wire and terminate the wire with the terminal lug at the 28VDC Buss. See Figure 61-25 for Buss location.

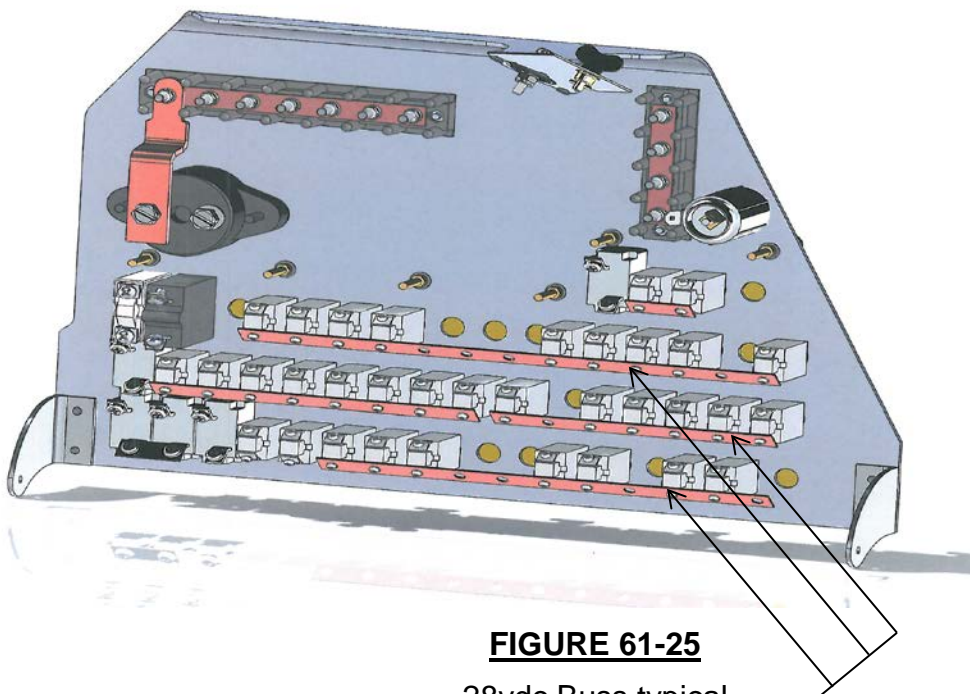
- f. Crimp another Terminal Lug MS25036-102 on the other end of the wire. The length of the wire should be 12 Inches. Terminate this end at the Circuit Breaker.
- g. Crimp (1) Terminal Lug MS25036-102 on the end of another 22 AWG wire and terminate the wire on the other side of the Circuit Breaker with the Terminal Lug.
- h. The wire just terminated should be cut to 76 inches long and be routed to Pin 2 of the fuel filter bypass light on the left hand instrument panel shown below.

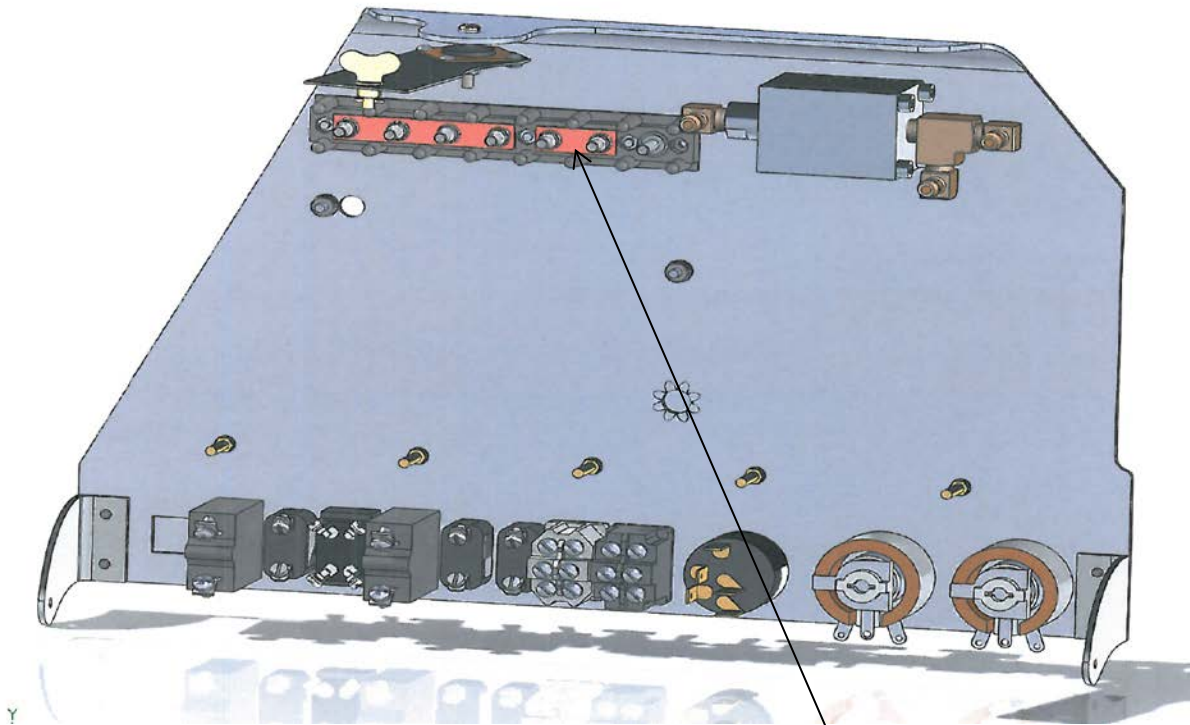


**FIGURE 61-24**

- i. Drill Dia. 0.471 hole to add a light.
- j. Assemble (1) MS25041-4 Amber Light in this location with a GE-327 Bulb on the Left Hand Instrument Panel Assembly as shown.
- k. Assemble (1) 21436-301 Fuel Filter Bypass Placard below the light.
- l. Solder the wire from step g above to pin 2 on the light.

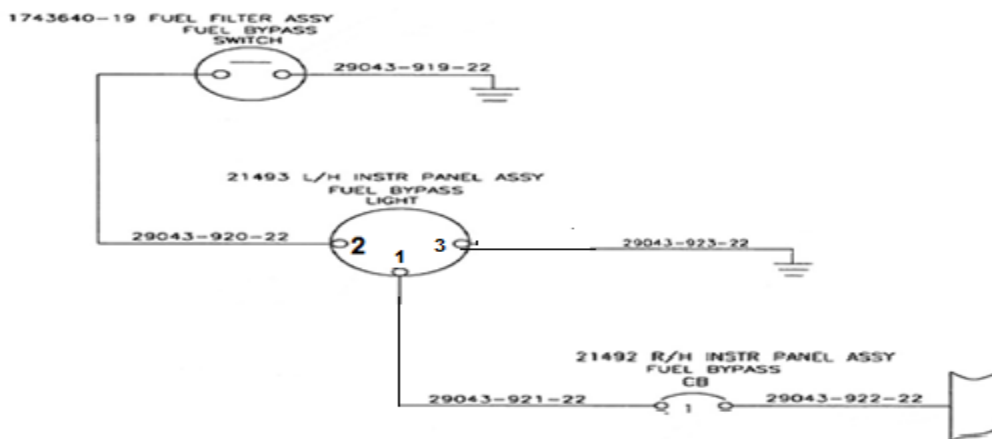
- m. Solder another 22 AWG Wire from pin 1 on the lamp. Crimp (1) Terminal Lug MS25036-103 on the other end and terminate it to the ground buss with the terminal lug. This wire should be 4 inches long. See Figure 61-26 for ground buss location.
- n. Solder another wire to pin 3 on the light. This wire will terminate at the Fuel Filter Assembly Fuel Bypass Switch and be soldered in the cannon plug. This wire shall be 110 inches long. See figure 61-14 for cannon plug.
- o. Solder the last 22 AWG wire into the other pin on the cannon plug and place a MS25036-103 Terminal Lug on the other end a route it to ground. The firewall serves as ground. This wire should be 6 inches long. See figure 61-14 for cannon plug.





**FIGURE 61-26**

Ground Bus Typical



**FIGURE 61-27**

**Schematic for Wiring Done In Section 15 Herein**

- p. Press the red fuel filter “Press To Test” switch and verify that the annunciation light on the left hand instrument panel, labeled “Fuel Filter Bypass, turns on.



- q. Turn airframe fuel shutoff valve to “ON” position. Turn main fuel pump on and observe operation in green range on MVP-50T. Observe fuel filter, fuel pump, and all hoses/adapters for leaks. Make corrections as necessary.
- r. Access the engine maintenance manual 0983402.
- s. Continue to Chapter 73-10-03 and page 202 and accomplish step 11; De-aerate the FCU.
- t. Perform engine run test and power plant performance check per Engine Maintenance Manual No. 0983402, Chapter 71-00-00 and pages 501-511.

## 15 SUPPORT DOCUMENTATION

- a. A revised Airplane Flight Manual, updated to the requirements specified herein, has been supplied with this service bulletin. This revised manual supercedes your existing manual. Replace you existing manual with this revised Airplane Flight Manual Revision A, or latest FAA approved revision.
  
- b. A revised Airplane Maintenance Manual, updated to the requirements specified herein, has been supplied with this service bulletin. This revised manual supercedes your existing manual. Replace you existing manual with this revised Airplane Maintenance Manual Revision 3, or latest approved revision.

## 16 RECORD OF COMPLIANCE

**Make appropriate entry in airplane maintenance records as follows:**

“Thrush Service Bulletin SB-AG-61 Rev. A complied with at \_\_\_\_\_

**total hours on aircraft. Modification accomplished by:**

\_\_\_\_\_.

(Name & Certificate #) (Date)

## 17 RESPONSE CARD

The final step in compliance with this Service Bulletin is to complete and return the compliance card on the next page. It may be mailed, Faxed, or scanned and e-mailed.

FAX to: Ed Rusk 229-439-9790

E-mail to: Ed Rusk [erusk@thrushaircraft.com](mailto:erusk@thrushaircraft.com)

**-Service Bulletin SB-AG-61 Rev. A Compliance Report**

Aircraft S/N:	_____	Aircraft Owner:	_____
Aircraft Registration #	_____	Address of Owner:	_____
Airframe total time:	_____	City & State:	_____
Engine total time:	_____	Physical location:	_____
Date of Compliance	_____		_____
Complied with by:	_____	Certificate #:	_____
Signature:	_____		

**PLEASE RETURN THIS REPORT ONLY AFTER REPAIR IS MADE**

This response card may be mailed, faxed to (229) 439-9790, or e-mailed to [erusk@thrushaircraft.com](mailto:erusk@thrushaircraft.com).

Fold, Tape & Mail (Do Not Staple) **Don't forget postage**

---

\_\_\_\_\_

\_\_\_\_\_

\_\_\_\_\_

Return Address

**THRUSH AIRCRAFT INC.**  
Attn: Ed Rusk  
300 Old Pretoria Road  
Albany, GA 31721